

Contribution to the design of ultra-frequency carriers for digital transmission in advanced telecommunications

Hamouda Amar¹, Hamla Amina², Djemil Cheima²

¹ MCB Department of Networks and Telecommunications, ISTA Ain Mila, Univ-OEB, Algeria.

Member of the Laboratory of Studies and Research of Instruments and Communications of Annaba (LERICA), Algeria.

² Master's degree in Applied Physics, SM Department, Faculty of Exact Sciences and Natural and Life Sciences, Univ-OEB, Algeria.

*Corresponding author, email : amarhamouda23@gmail.com

Abstract

Our goal of this work is the realization by simulation the production of a train of optical pulses in order to improve the factors that influence the parameters of the optical fiber material, which determine the flow of information and data to be transmitted, very high speed at very long distances by fiber or in the form of radio beams using dispersive and non-linear regimes by the OTDM technique, in order to improve the performance of the transmission chain, thus, the security and protection of the transmitted signal against noise, interference and distortion.

Keywords : optical pulses, the flow, high speed, non-linear, OTDM technique.

I. Introduction

At present, the most efficient and widespread technology is based on optic-fiber transmission systems. The latter offer a physical support with low attenuation, almost insensitive to electromagnetic noise, easy installation and high transmission capacities.

The starting point of telecommunications by optical fibers is undoubtedly the invention and development in the 60s of LASER [1, 2] which, by their compactness, their quasi-monochromatic and their high power, have the advantage of being able to be injected into a waveguide. The race to the ever further was then launched and was never to know an end. Fiber optics, as we currently use it, are the result of intensive research on new weakly dissipative waveguides.

Thanks to rapid advances in chemistry, very low loss coefficients of the order of 0.2dB/km around 1550 nm were reached in the 70s, bringing to 95% the amount of light conveyed after 1km of propagation. At the same time, the theoretical discovery of the optical soliton in 1973 by Hasegawa and Tappert [2], then of its experimental observation in 1980 by Mollenauer and his collaborators [2, 3] are landmarks in the history of telecoms. Indeed, researchers and industrialists were therefore able to propagate a pulse without deformation at the speed of light, over very long distances and with a wide bandwidth.

One of the main challenges of all-optical regeneration for future telecommunications networks is therefore to achieve a compact 2R regenerator that can remove the maximum noise from a signal whose rate can exceed 40 Gbits/s. For such speeds, electronics have reached their limits and are therefore no longer competitive. The use of an all-optical regeneration technique is therefore essential. A technique called Mamyshev [4, 5] is currently considered one of the most promising.

Digital transmission systems convey information between a source and a recipient using a physical medium such as cable, optical fiber or propagation over a radio channel. The signals transported can be either directly of digital origin, as in data networks, or of analog origin (speech, image ...) but converted into a digital form. The task of the transmission system is to convey information from the source to the recipient as reliably as possible [6].

With the rapid evolution of telecommunications services accessible to users, such as multimedia services enriched with very high-speed Internet, IPTV (Internet Protocol Television), video telephony, high-definition television and home networks. All these services will thus have to carry data streams reaching gigabit per second [6, 7].

II. Theoretical study

II.1. Block diagram of the generator

This generator consists of four blocks (modules) integrating electronics and optoelectronic functions, each of which has a well-defined role (see figure 1).

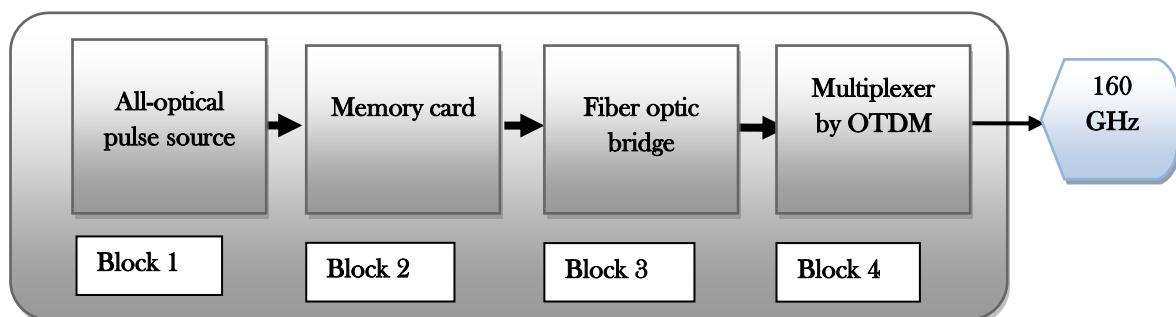

Figure 1. Descriptive diagram of the generator.

II.1.1. Block 1

This block (see Figure 2) represents a source of very high-speed picosecond optical pulses [8, 9].

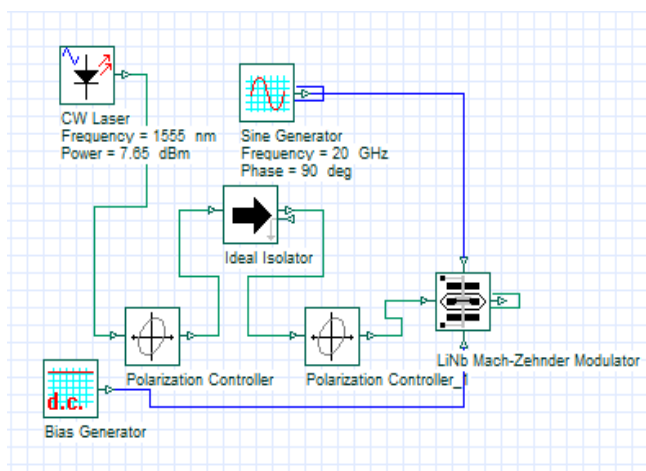

Figure 2 Source of picosecond optical pulses [8].

II.1.2. Block 2

This part incorporates a RAM-type memory card containing a program that specifies one of the three positions of the three optical fiber ends and the start-up (see figure 3).

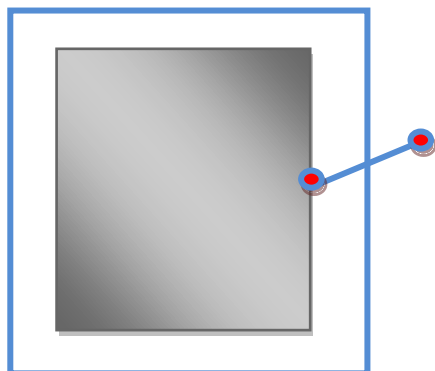

Figure 3. Memory card containing the program.

II.1.3. Block 3

This block contains two optical fibers in parallel (see Figure 4), the first of which had the property of imbalance between the effect of nonlinearity and chromatic dispersion of order 2 [10, 11] and the effect of nonlinearity [12, 13, 14], so that the first is greater than the second, and vice versa in the second optical fiber.

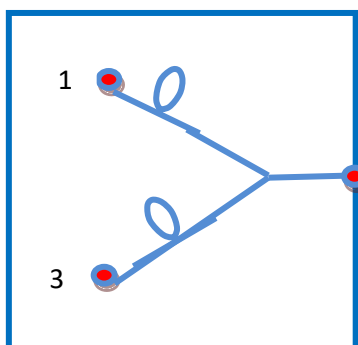

Figure 4. Fiber optic bridge.

II.1.4. Block 4

This block is a multiplexer (see figure 5) by the OTDM method [15, 16, 17] constitutes three stages, the temporal multiplexing is a method for multiplying the flow rate. It consists in interlacing several bit frames from offset sources. This technique is known as OTDM (Optical Time Division Multiplexing).

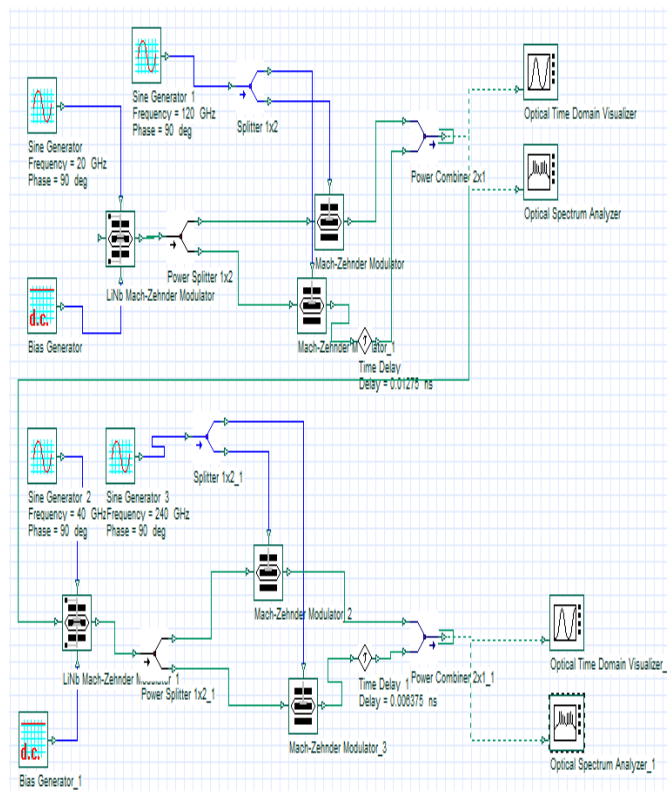

Figure 5. Multiplexer by the OTDM method.

II.2. Expressions of graders of the properties of optical fibers

II.2.1. Chromatic dispersion of order two

This phenomenon is considered harmful in the field of optical telecommunications, because it induces a temporal enlargement of the pulses (the information to be transmitted) during their propagation [18], which subsequently causes their overlap.

β_2 , it is responsible for the temporal enlargement of the pulses also known as the dispersion coefficient of the group velocity GVD (Group Velocity Dispersion), it reflects the variation of the speed vis-à-vis the frequency [19, 20].

$$\beta_2 = \left(\frac{\partial^2 \beta}{\partial \omega^2} \right)_{(\omega=\omega_0)} = \frac{1}{v_g^2} \frac{\partial v_g}{\partial \omega} = \frac{1}{c} \left[2 \frac{\partial n}{\partial \omega} + \omega \frac{\partial^2 n}{\partial \omega^2} \right], \quad (1)$$

The chromatic dispersion or any short dispersion, denoted D , represents the deviation of the arrival time of two pulses of different central wavelengths of 1 nm and sent in a fiber of 1 km of lengths. This quantity can be expressed as a function of β_2 , (in ps.nm⁻¹.km⁻¹).

$$D = -\frac{\pi}{\lambda^2} \beta_2, \quad (2)$$

With C is the speed of light and λ is the wavelength.

L_D is the dispersion length, corresponding to the propagation distance at the end of which the initial pulse, of a temporal width at 1/e of T_0 , has widened or spread by a factor $\sqrt{2}$.

It is important to know the length for which the effect of dispersion, of order 2, becomes important, or :

$$L_D = \frac{T_0}{|\beta_2|}, \quad (3)$$

II.2.2. Kerr effect

This phenomenon of birefringence [21, 22] provoked, discovered by Kerr (in 1875), is known as the Kerr effect. This phenomenon has a remarkable feature, the Kerr coefficient is expressed by :

$$\gamma = \frac{\omega_0 \cdot n_2}{c \cdot A_{eff}}, \quad (4)$$

Or ω_0 : is the frequency of the carrier,

A_{eff} : corresponds to the effective area of the optical fiber.

$$\text{With } n_2 = \frac{2n_{NL}}{\epsilon_0 c n}, \quad (5)$$

n_2 represents the nonlinear index, n_{NL} the nonlinear refractive index.

We can define the L_{NL} parameter, as in the case of dispersive effects, the length of fiber for which nonlinear effects become important :

$$L_{NL} = \frac{1}{\gamma P_0}, \quad (6)$$

P_0 is the peak power of the fundamental soliton ($N = 1$) [23] connected to the parameters of the optical fiber by the criterion $L_D = L_{NL}$.

Remark

The solitonic regime is carried out for :

$$L_D = L_{NL} \quad (7)$$

We are talking about a purely non-linear regime for :

$$L_{NL} \gg L_D, \quad (8)$$

Is carried out purely dispersive regime for :

$$L_D \gg L_{NL} \quad (9)$$

II.2.3. Parameters of the optical fibers used

From equations (1,...,9), one can find the values and parameters of the components of the assembly (see Table 1 and Table 2).

Tab. 1 The properties and characteristics of the four optical fibers.

Optical fibers	Chromatic dispersion of order 2 (β)	Kerr effects (γ)	Fiber length (L)
Fiber 1	17 ps/(nm.Km)	1.7 W ⁻¹ .Km ⁻¹	2.18 Km
Fiber 2	17 ps/(nm.Km)	1.95 W ⁻¹ .Km ⁻¹	1.95 km
Fiber 3	17 ps/(nm.Km)	0.85 W ⁻¹ .Km ⁻¹	1.44 km
Fiber 4	-100 ps/(nm.Km)	1.3 W ⁻¹ .Km ⁻¹	1.4 km

Tab. 2 Values and parameters of the components of the simulated assembly.

component	parameter	symbol	value
Laser source	Longueur d'onde	L	1555 nm
	puissance	P	6.95 dBm
Mach-Zehnder 1 modulator	Tension d'extinction	zU_{ext}	23 v
	Tension de bias	V_b	9.5 v
Mach-Zehnder 2 modulator	Tension d'extinction	U_{ext}	29 v
	Tension de bias	V_b	4.68 v
EDFA 1 amplifieur	Puissance de sortie maximale	$P_{s,max}$	13 dBm
EDFA 2 amplifieur	Puissance de sortie maximale	$P_{s,max}$	28 dBm

II. 3. Generator memory card algorithm and program

The automation of this multi-speed generator is carried out according to a program from this algorithm (see alg. 1).

Alg. 1 Algorithm for multi-speed generator automation

experimental elements such as signals recorded with measuring devices or curves characteristic of real components. In all that follows the simulation tool used is the OPTISYSTEM version 7 [24, 25].

IV. Results and Discussions

From the work [8] Simulation of an all-optical source flowing ultra-high-speed pulses (160 Gb/s), was carried out in solitonic regime according to the equilibrium condition between the dispersive effect and that of the nonlinearity within the main optical fiber (see Figures 6, 7 and 8), this is checked for the relationship ($L_D = L_{NL}$).

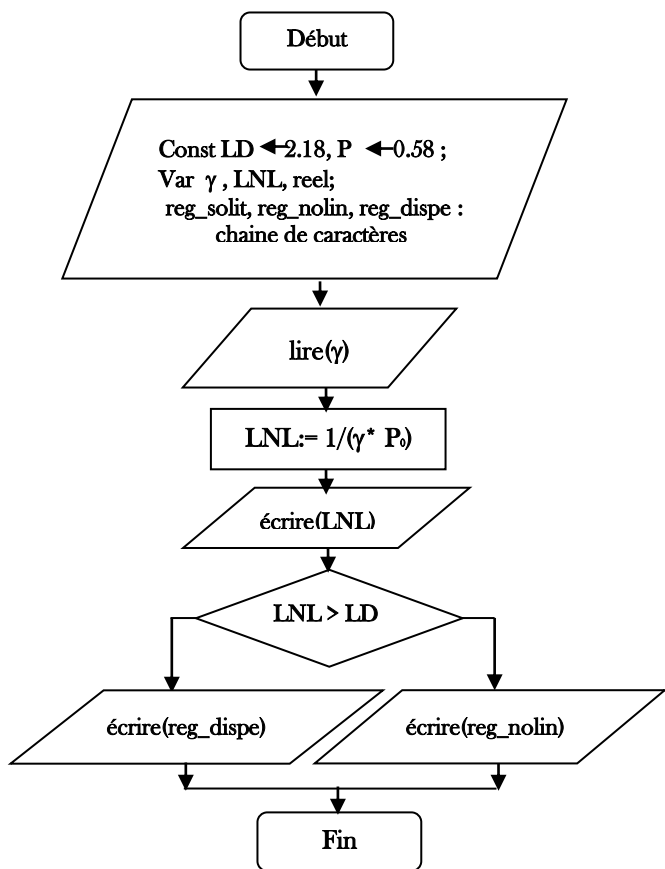

```

Program(multi_régimes)
Const
LD ← 2.18; P₀ ← 0.58;
var
γ, LNL : reel;
reg_solit, reg_nolin, reg_dispers : string;
Begin
Readln(γ);
LNL := 1/(γ * P₀);
Writeln(LNL);
If LNL > LD then writeln(reg_nolin);
else
writeln(reg_dispers);
end,
end,
End.
  
```

III. Digital simulation

Faced with the increasing complexity of the architectures and systems developed, simulation tools have acquired an important role. They are increasingly used to optimize the parameters involved in the realization of a system. They make it possible to predict results expected experimentally. They now also make it possible to use during a simulation,

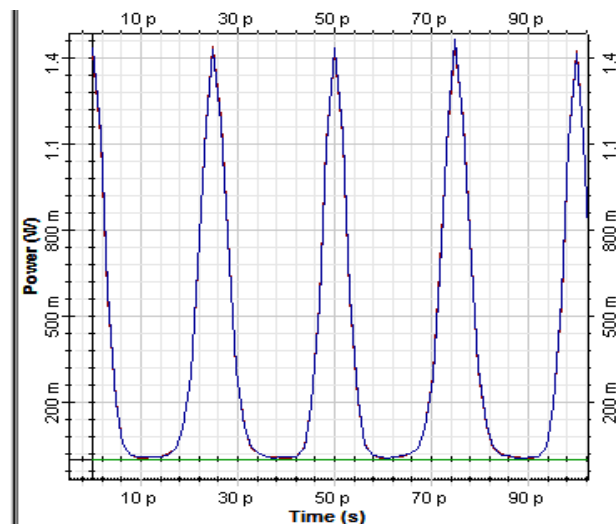

Figure 6. The pulse train at 40 Gb/s at the output of the generator according to condition [8].

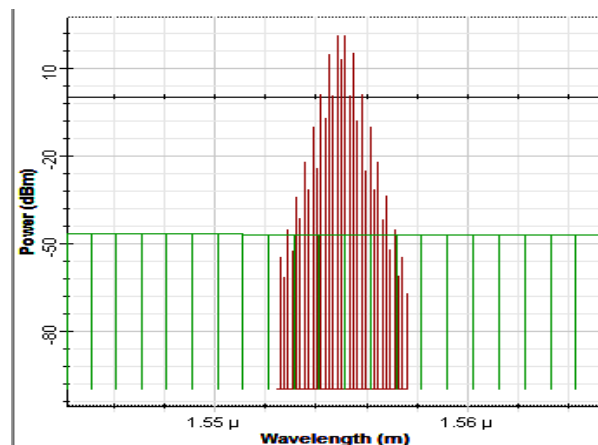

Figure 7. Spectrum of the signal at the output of the first block in solitonic regime [8].

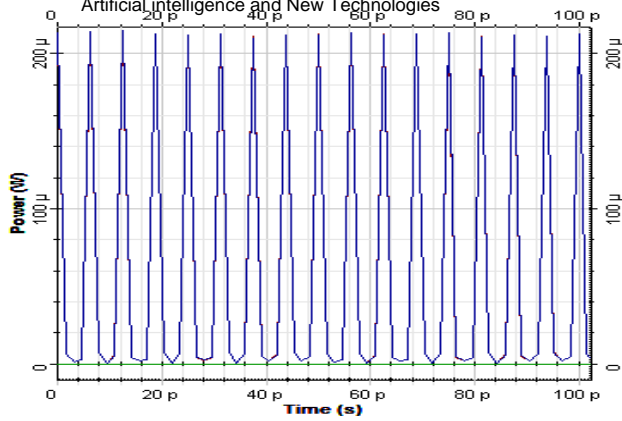

Figure 8. The pulse train at 160 Gb/s at the output of the generator according to the condition[8].

The replacement of this fiber by another that satisfies the condition ($L_D < L_{NLN}$) makes it possible to produce a train of light pulses in non-linear mode is the semilariton form (see figures 9 and 10), after multiplexing by the OTDM method [26, 27, 28], the self-modulation process was obtained (see figure 11).

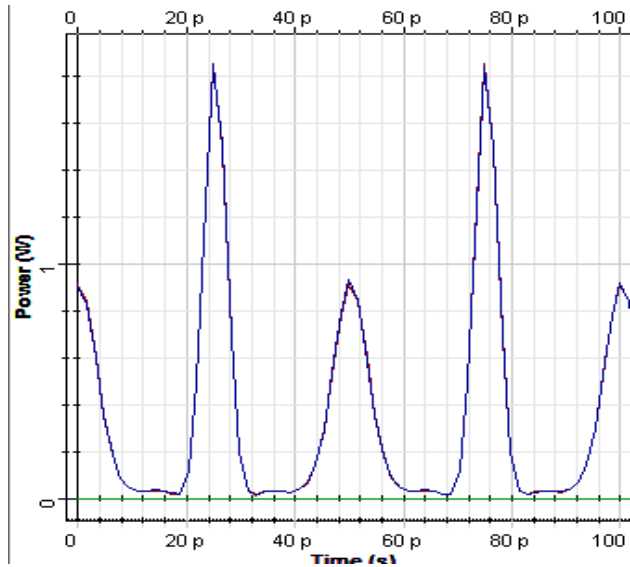

Figure 9. The pulse train at 40 Gb/s at the output of the generator according to the first condition.

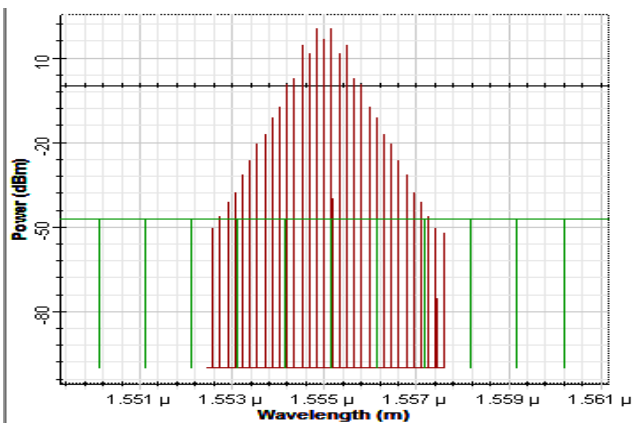

Figure 10. Spectrum of the signal at the output of the first block in non-linear mode.

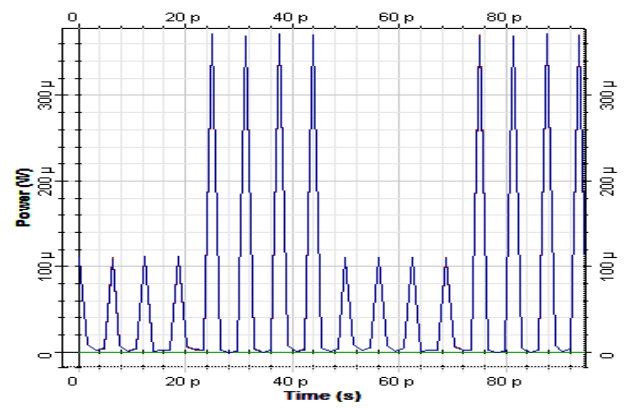

Figure 11. The pulse train at 160 Gb/s at the output of the generator according to the first condition.

Again the last fiber was changed by a third which verified the inverse of the previous condition ($L_D > L_{NLN}$), this provided a train of optical pulses in dispersive regime (see figures 12 and 13), the start of the train would be increased after passing through the multiplexer[29, 30] had become a self-modulated signal (see Figure 14).

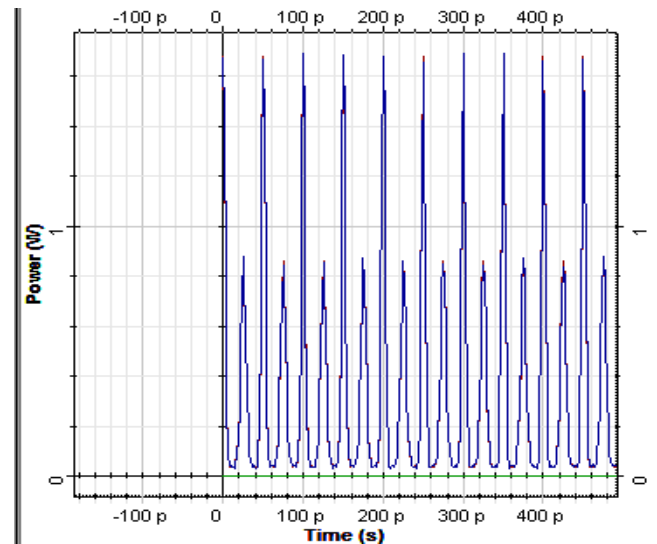

Figure 12. The pulse train at 40 Gb/s at the output of the generator according to the first condition

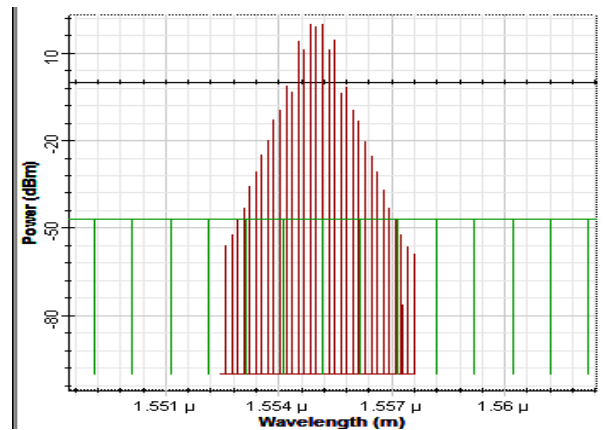

Figure 13. Spectrum of the signal at the exit of the first block in dispersive regime.

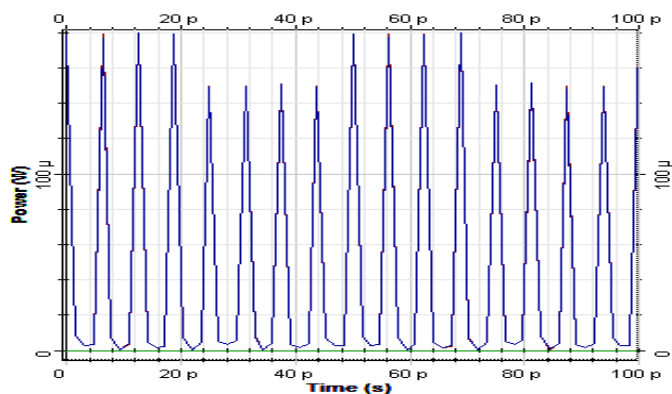

Figure 14. The pulse train at 160 Gb/s at the output of the generator according to the second condition.

The switching from one of the two optical fibers to the other is performed automatically according to a program recorded in the memory card inserted in the generator assembly (see figures 1 and 3).

V. Conclusion

This work based on the development and improvement of the generator [8], the latter consisted in carrying out the pulse train in solitonic regime by the balance between the effect of non-linearity and that of chromatic dispersion of order two within the optical fiber, two other fibers of the same types and properties were added, the first providing the train in nonlinear mode according to a very specific condition at the level of the equilibrium of the two effects within this optical fiber, the second fiber ensures the inverse of the previous condition to generate the pulse train in highly dispersive regime, the start of one of the two optical fibers is carried out thanks to a program in a memory card inserted in the assembly of the previous generator.

References

[1] T. H. Maiman, "Stimulated optical radiation in Ruby masers", *Nature*, vol. 187, pp. 493, 1960.

[2] A. Hasegawa and F. Tappert, "Transmission of stationary nonlinear optical pulses in dispersive dielectric fibers, I. Anomalous dispersion", *Appl. Phys. Lett.*, vol. 23, pp. 142, 1973.

[3] L. F. Mollenauer, R. H. Stolen, and J. P. Gordon, "Experimental Observation of Picosecond Pulse Narrowing and Solitons in Optical Fibers", *Phys. Rev. Lett.*, vol. 45, pp. 1095-1098, 1980.

[4] P. V. Mamyshev, «All-optical data regeneration based on self-phase modulation effect», in *European Conference on Optical Communication, ECOC'98*, p 475- 476. Madrid, Spain, 1998.

[5] P.V. Mamyshev, S.V. Chernikov, and EM Dianov, "Generation of fundamental soliton trains for high-bit-rate optical fiber communication lines", *Journal of Quantum Electronics, IEEE*, 27(10):2347-2355, 1991.

[6] <http://www.enseirb.fr/~kadionik>.

[7] V. Girondin, «Etude et modélisation d'un modulateur à électro-absorption pour des applications de transmission radio sur fibre de signaux ULB aux fréquences centimétriques- Simulation système et caractérisation d'une liaison radio sur fibre à modulation externe», Thèse de doctorat, Université Pierre et Marie Curie, 2016.

[8] A. Hamouda, K. Saouchi, 2017. Breves generator of pulses has different flow rates(40 Ghz, 80 Ghz and 160 Ghz), *journal of JNTM*, Vol. 7(01), p. 27-32.

[9] A. Hamouda, K. Saouchi, 2017. Simulation d'une source tout optique débitant des impulsions à ultra-haut débit (320 Gb/s), *Rev. Sci. Technol., Synthèse*, Vol 35, p. 224-232.

[10] S. O. Mohammadi, S. Mozaffari and M. M. Shahidi, "Simulation of a transmission system to compensate dispersion in an optical fiber by chirp gratings", *International journal of the Physical Sciences*, 6(32), 7354-7360, 2011.

[11] D. Wake, C. R. Lima and P. A. Davies, «Optical generation of millimeter-wave signals for fiber-radio systems using a dual-mode DFB semiconductor laser», *IEEE Transactions on Microwave Theory and Techniques*, vol. 43, no. 9, p. 2270-2277, 1996.

[12] M. F. Ferreira, "Nonlinear effects in optical fibers", volume 2. Wiley. com, 2011.

[13] T. Hirooka, S. Ono, K.-I. Hagiuda, and M. Nakazawa, "Stimulated Brillouin scattering in dispersion-decreasing fiber with ultrahigh-speed femtosecond soliton pulse compression", *Opt. Lett.*, 30(4):364-366, 2005.

[14] T. Inoue, J. Hiroishi, T. Yagi, and Y. Mimura, "Generation of in-phase pulse train from optical beat signal", *Opt. Lett.*, 32(11):1596-1598, 2007.

[15] J. Fatome, S. Pitois, C. Fortier, B. Kibler, C. Finot, G. Millot, C. Courde, M. Lintz and E. Samain, 2010. Multiple four-wave mixing in optical fibers: 1.5-3.4-THz femtosecond pulse sources and real-time monitoring of a 20-GHz picosecond source, *Opt. Commun*, vol. 283, pp. 2425-2429.

[16] A. Takada and M. Saruwatari, 1988. 100Gbit/s optical signal generation by time-division multiplication of modulated and compressed pulses from gain-switched distributed feedback (DFB) laser diode, *Electronics Letters*, vol. 24(23), p.1406-1408.

[17] S. Wabnitz and N. Akhmediev, 2010 . Efficient modulation frequency doubling by induced modulation instability, *Optics Communications*, vol. 283(6), p. 1152-1154.

[18] G. P. Agrawal, 2001. Applications of Nonlinear Fiber Optics, Third edition. New York Academic press, 467 p.

[19] P. Bédot, B. Kibler, E. Hertz, B. Lavorel and O. Faucher, 2011. General approach to spatiotemporal modulational

- instability processes, *Physical Review A*, Vol. 83(1), p. 138-145.
- [20] R. W. Boyd, 2008. Nonlinear optics, Academic press, 3rd edition Paris. 173p.
- [21] A. Hasegawa, 1984. Generation of a train of soliton pulses by induced modulational instability in optical fibers, *Opt. Lett.*, vol. 9(7), p. 288-290.
- [22] A. Hasegawa and W. Brinkman, 1980. Tunable coherent IR and FIR sources utilizing modulational instability, *Journal of Quantum Electronics, IEEE*, vol. 16(7), p.694-697.
- [23] K. Inoue, , 1992. Four-wave mixing in an optical fiber in the zero-dispersion wavelength region, *Journal of Lightwave Technology*, vol. 10(11), p. 1553-1561.
- [24] N. Nishizawa and T. Goto, 2006. Novel super-continuum fiber lasers and wavelength-tunable soliton pulses, SPIE Newsroom.
- [25] S. O. Mohammadi, S. Mozaffari and M. M. Shahidi, 2011. Simulation of a transmission system to compensate dispersion in an optical fiber by chirp gratings, *International journal of the Physical Sciences*, Vol. 6(32), 7354-7360.
- [26] V. Kaman and J. E. Bowers, 2000. 120 Gbit/s OTDM system using electroabsorption transmitter and demultiplexer operating at 30GHz, *Electronics Letters*, Vol. 36(17), 1477-1479.
- [27] Y. K. Chen, C. J. Hu, C. C. Lee, K. M. Feng, M. K. Lu, C. H. Chung, Y. K. Tu and S. L. Tzeng, 2000. Low-crosstalk and compact optical add-drop multiplexer using a multiport circulator and fiber Bragg gratings, *IEEE Photonics Technology Letters*, Vol. 12, 1394-1395.
- [28] A. D Errico, C. Loiacono, M. Presi, G. Contestabile and E. Ciaramella, 2003. Widely tunable 40 GHz pulse source for 160 Gbit/s OTDM by simultaneous soliton generation and compression, In: European Conference and Exhibition on Optical Communication (ECOC) IEEE, p. 578-580.
- [29] S. Trillo, S. Wabnitz, and T. A. B. Kennedy, 1994. Nonlinear dynamics of dual-frequency-pumped multiwave mixing in optical fibers, *Physics. ReviewA*, Vol. 50(2), 1732-1747.
- [30] C. Chluda, 2006. Bruit basse et moyenne fréquence des amplificateurs optiques distribués à effet Raman, PhD thes Multiplexeur par OTDM is on physics, university of Montpellier 2, France, 187p.